

interact Pro



LCN1840/05

Wireless gateway

Specification sheet

Find out more about Interact
www.interact-lighting.com/pro

Works with

Connected lighting

PHILIPS

LCN1840/05

The Interact Pro wireless gateway (WG) is the basis of the lighting system and connects the system to the cloud via the internet. The IP backbone between the WG enables communication between the luminaires and the cloud. The WG connects with the luminaires by means of ZigBee.

Product description

The WG features an easy commissioning process during initial installation and is ready for later expansions.

The WG is powered by a 5 Vdc Class 2/SELV power adapter. The system is easily scaled up by connecting multiple WGs over Ethernet.

Wireless communication complies with the ZigBee Pro standard (IEEE 802.15.4, WPAN) in the 2.4 GHz frequency band. The WG must be placed within 10 m (33 ft) from one or more of the ZigBee luminaires to form a mesh network. Communication between Philips Lighting wireless devices and the WG is encrypted, as well as the communication between the WG and the devices on the Interact Pro network.

The WG establishes a secure wireless ZigBee connection with at average 200 end points. The wireless connections allows for bidirectional control and sensor data exchange between the end points and the Interact Pro network.

Features and benefits

- White enclosure, mounting bracket
- 3 LED indicators for feedback on power, connectivity, and communication
- Has unique QR code for install and commissioning
- Controls associated end points without access to cloud (lighting behavior)
- Lighting behavior of end devices remains operational upon failure
- Can be remotely managed, upgraded, and controlled
- The underlying lighting network will implement graceful degradation upon failures
- Secure wireless communication based on the ZigBee PRO standard (IEEE 802.15.4, WPAN) operating at 2.4GHz radio frequency (RF)
- Functions for the WG and all connected devices can be modified with software configurable settings

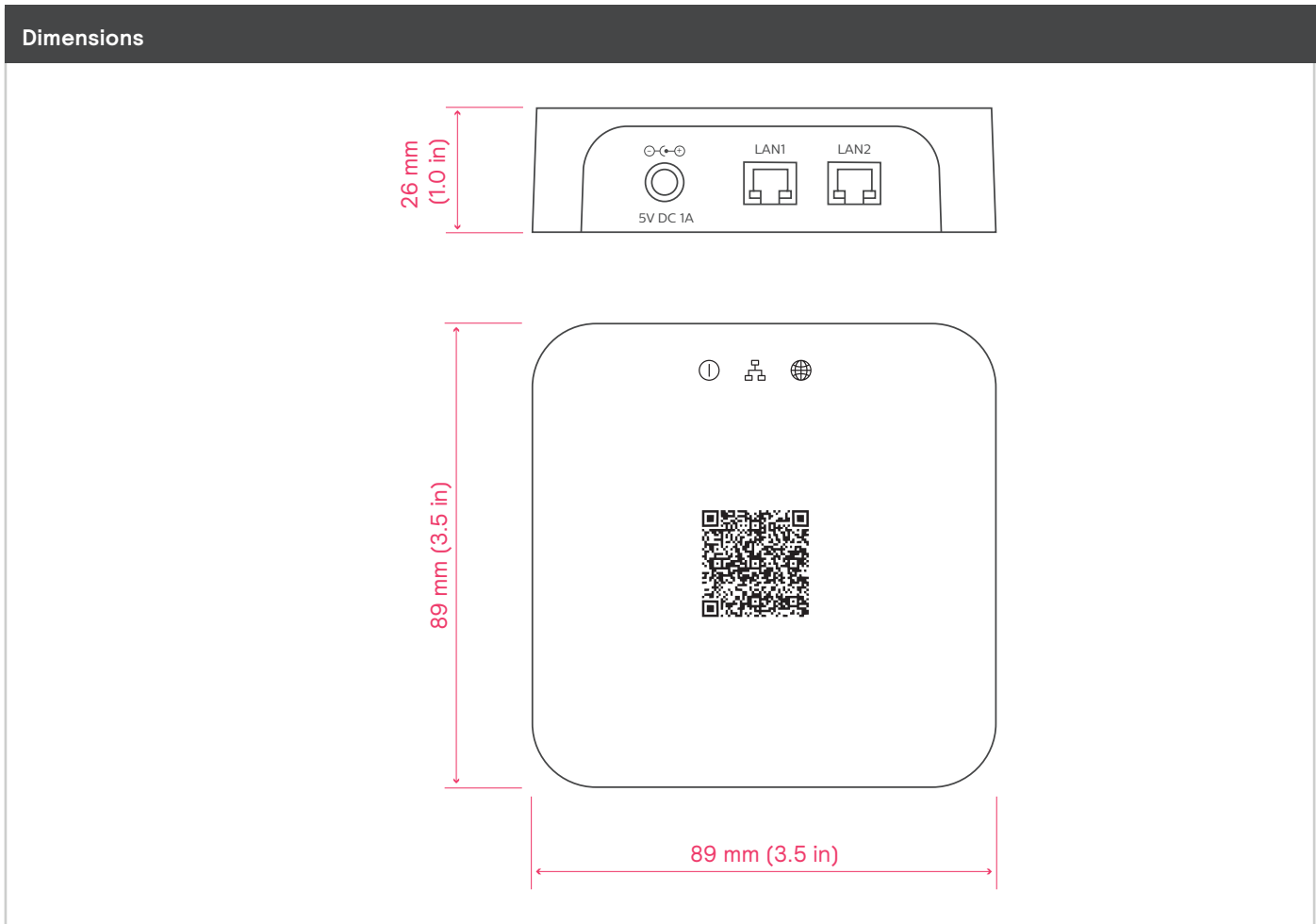

Wireless communication

The wireless network is based on the ZigBee PRO standard (IEEE 802.15.4, WPAN) which is targeted at radio-frequency (RF) applications and operates at 2.4 GHz. The ZigBee protocol enables fully distributed peer-to-peer communication models. This means no master/ slave relationship whereby the application is divided over the devices in the network. Every device knows how it functions within the network. The result is that if one device does not function (removed or defect), the remaining devices keep functioning as intended.

The network is based on a mesh network, so devices pass on the received commands. The distance between the devices should not exceed 10 m (33 ft). The advantage of a mesh network is the capability for self-healing routing, enabling automatic route discovery over the mesh network. ZigBee has tolerance for a large number of co-located networks due to use of multiple communication channels and CSMA-CA channel access. The commands have network security according to AES 128-bits network encryption. Other connected lighting wireless devices like the kinetically-powered ZigBee Green Power (ZGP) Switches make use of the same protocol so they can be combined to interact in a seamless way.

The WG supports encrypted and secure wireless network communication. Third party ZigBee devices can only join the ZigBee network if their unique identifiers are explicitly enabled in the Interact Pro system.

Note

Wireless signals may be subject to radio frequency interference.

Application area

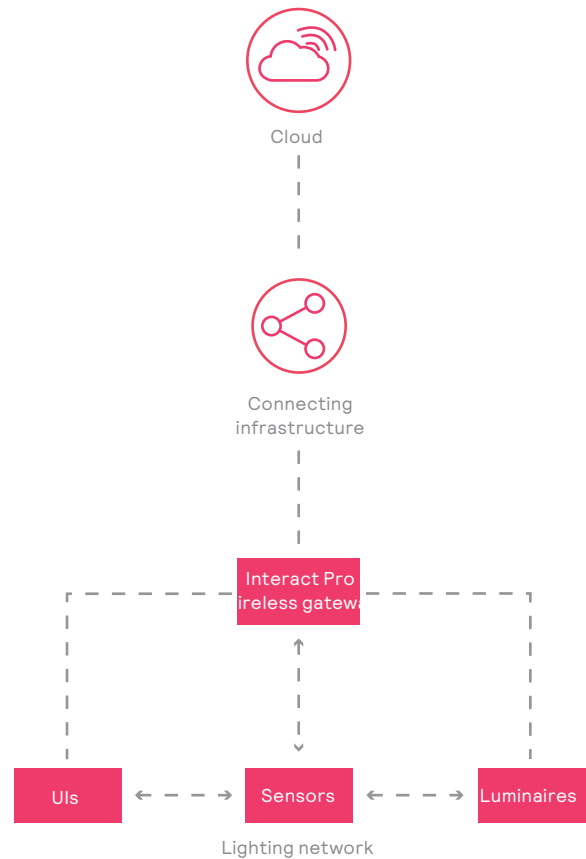

Electrical diagram

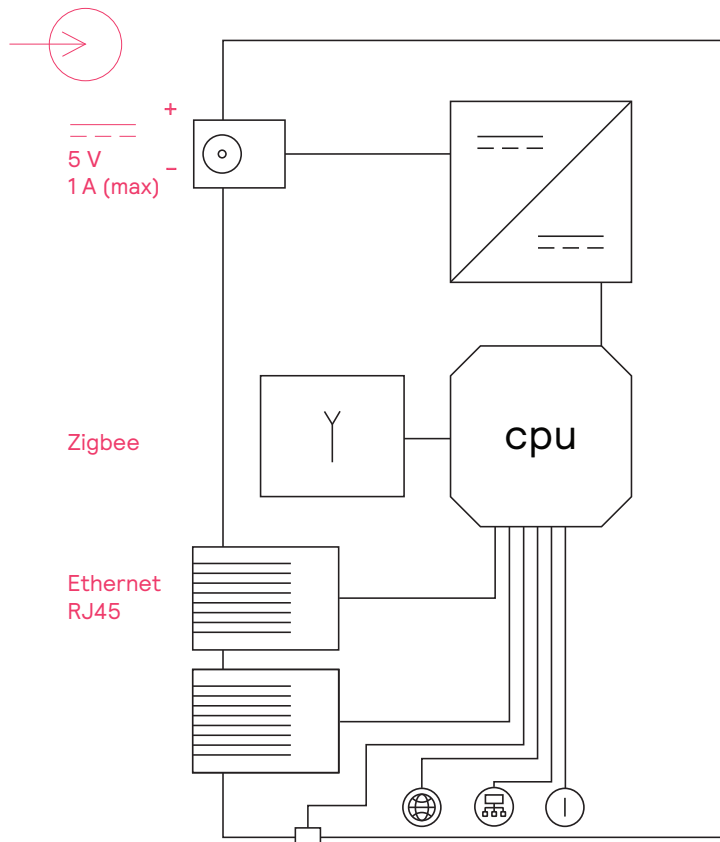

Specifications

General characteristics		
Supply options		
Power supply	In: 100-240 Vac, 50/60 Hz Out: 5 Vdc Class 2/SELV; 1 A	
Allowed supply ripple	Max. 0.5 Vpp	
Power consumption	Max. 2.5 W	
Communication ports	2x 10/100 BaseT Ethernet port ZigBee port	
Supported Ethernet protocols	IPv6, TCP, UDP	
Environmental conditions operating		
Ambient temperature range	-20 to 45°C (-4 to 113 °F)	
Relative humidity range	0 to 80%, non-condensing	
Environmental conditions storage		
Temperature range	-40 to 80°C (-40 to 176 °F)	
Relative humidity range	10 to 90%, non-condensing	
Connector type		
Supply in	1x DC plug 5.5 mm (0.2 in)	
Ethernet	RJ45	
Wireless communication	ZigBee PRO standard (IEEE 802.15.4, WPAN)	
Housing		
Material	ABS	
Color	Signal white (RAL9003)	
Dimensions (length, width, height)	91 × 91 × 26 mm (3.6 × 3.6 × 1 in)	
Weight	95 g (0.21 lb) (incl. mounting bracket)	
Power adapter	Power Plug SELV/Class2 Exchangeable Plugs for EU & NA mains socket	Universal Mains 100-240 VAC 50/60 Hz Length of cable 1.5m
Mounting bracket		
Material	ABS	
Color	Signal white (RAL9003)	
Dimensions (length, width, height)	97 × 97 × 34 mm (3.8 × 3.8 × 1.3 in)	
User controls	Reset Push Button, Status LEDs (Power, Network, Portal)	
Real time clock	Mains / Battery powered Battery life: 2 years no supply / 10 years with supply	

Regulatory compliance

Certifications

Approbation (Europe)	UL, CE, FCC, IC
R&TTE RF	ETSI EN 300 328 EN 62331
R&TTE EMC	ETSI EN 301 489-1/17 EN 55022 EN 55024 EN 55032
Approbation (US & Canada)	FCC Part 15.247; 15.107; 15.109 IC RSS-247 ICES-003
Safety	EN 60950-1 (UL60950-1 & CAN/CSA-C22.2 No. 60950-1-07)
Immunity	IEC 61000-4-2, 3, 4, 5, 6, 8, 11
Reliability	IEC60068
Environmental standard	ROHS/Reach



Packing data

Type	Dimensions	Qty/Box	Material	Weight (net)	Weight (gross)
LCN1840	110 × 80 × 110 mm (4.3 × 3.1 × 4.3 in)	1	Cardboard	0.18 kg (0.40 lb)	0.31 kg (0.68 lb)

Ordering data

EU Version

Type	MOQ	Ordering number	EAN code level 1	EAN code level 3	EOC
LCN1840/05 Interact Pro wireless gateway IA Pro L	1	9137 010 37703	8718696 775790	8718696 775806	775790 00

US Version

Type	MOQ	Ordering number	UPC code level 1	UPC code level 3	Catalog code
LCN1840/05 Interact Pro wireless gateway IA Pro L NA	1	9137 010 37713	046677 476335	50046677476330	LCN1840/05

Find out how Interact can transform your business
www.interact-lighting.com/pro

interact

© 2018 Signify Holding. All rights reserved. Signify reserves the right to make changes in specifications and/or to discontinue any product at any time without notice or obligation and will not be liable for any consequences resulting from the use of this publication.

INt-1807LF - Date of release: version 1 - 10th April 2018